

**PRODUCT** : CAMERA MODULE

**MODEL NO.** : CM5280-O500BA-E

**SUPPLIER** : TRULY OPTO-ELECTRONICS LTD.

**DATE** : May 15, 2010



CERT. No. 946535

ISO9001

TL9000

# SPECIFICATION

Revision: 0.2

**CM5280-O500BA-E**

If there is no special request from customer, TRULY OPTO-ELECTRONICS LTD. will not reserve the tooling of the product under the following conditions:

1. There is no response from customer in two years after TRULY OPTO-ELECTRONICS LTD. submit the samples;
2. There is no order in two years after the latest mass production.

And correlated data (include quality record) will be reserved one year more after tooling was discarded.

**TRULY OPTO-ELECTRONICS LTD.:**      **CUSTOMER:**

Quality Assurance Department: \_\_\_\_\_

Approved by:

Technical Department: \_\_\_\_\_

Approved by:



# CONTENTS

- n KEY INFORMATION
- n AUTO-FOCUS SPECIFICATION
- n PIN ASSIGNMENT
- n ELECTRICAL CHARACTERISTICS
- n MECHANICAL DRAWING
- n APPEARANCE SPECIFICATION
- n IMAGE SPECIFICATION
- n QA PLAN
- n PRECAUTIONS FOR USING CCM MODULES
- n PACKAGE SPECIFICATION
- n PRIOR CONSULT MATTER
- n FACTORY CONTACT INFORMATION

WRITTEN BY	CHECKED BY	APPROVED BY
HUANG WEI NA	WEI YOU XING	LIU TIE NAN

**Auto-Focus Specification**

NO.	Item	Specification
1	VCM Driver	AD5820
2	Auto-Focus Type	VCM (Voice Coil Motor)
3	Power Supply	2.6~3.3 V
4	Rated Current	≤80mA
5	Resistance	23±3Ω
6	Settling Time	<30ms
7	Hysteresis	≤±10μm
8	Focusing Range	10cm to infinity
9	Life Time	TBD

**Key Information**

Module No.		CM5280-O500BA-E
Module Size		8.5mm X 8.5mm X 5.00mm
Sensor Type		OV5647
Array Size	QSXGA	2592 X 1944
Power supply	core	1.5V + 5%
	Analog	2.6 ~ 3.0V (2.8V typical)
	I/O	1.7~3.0V
Lens		1/4 inch 4Plastic+ IR
Focus(F.NO)		2.8
View Angle		67.4°
Image Area		3673.6 μm x 2738.4 μm
Object distance		10cm-infinity
Sensitivity		TBD
Pixel size		1.4μm x 1.4μm
IR Cutter		650+/-5nm
Sensor Temperature Range	Operating	-30° C to 70° C
	Stable Image	0° C to 50° C
Output Formats		10-bit RGB RAW output
Maximum Image Transfer Rate	QSXGA	15 fps
	VGA	60 fps
	QVGA	120 fps
S/N Rate		TBD
Dynamic Range		TBD
substrate		PCB
IC Package		wafer
Sensor Power requirement	Active	TBD
	Standby	TBD
Fixed Pattern noise		TBD
Dark current		TBD
Package		Antistatic Plastic

## Pin Assignment

No.	Name	Pin type	Description
1	FLASH	I/O	Flash control
2	DGND	Ground	Ground for digital circuit
3	CAM_ID	I/O	Camera Identification
4	D9	I/O	Video port output bit[9]
5	D8	I/O	Video port output bit[8]
6	D7	I/O	Video port output bit[7]
7	D6	I/O	Video port output bit[6]
8	D5	I/O	Video port output bit[5]
9	D4	I/O	Video port output bit[4]
10	DGND	Ground	Ground for digital circuit
11	DGND	Ground	Ground for digital circuit
12	VSYNC	I/O	DVP VSYNC output
13	HREF	I/O	DVP HREF output
14	PWDN	Input	Power down, active high with internal pull-down resistor
15	PCLK	I/O	DVP PCLK output
16	DGND	Ground	Ground for digital circuit
17	AF_VDD	Power	Power for VCM
18	AVDD	Power	Power for analog circuit
19	AGND	Ground	Ground for analog circuit
20	MCLK	Input	System clock input
21	RESET	Input	hardware reset (active low with internal pull-up resistor)
22	DOVDD	Power	Power for I/O circuit
23	DVDD	Power	power for digital core circuit
24	SIOD	I/O	SCCB data
25	SIOC	Input	SCCB input clock
26	AF_PWDN	Input	Power down control for VCM
27	DGND	Ground	Ground for digital circuit
28	D3	I/O	Video port output bit[3]
29	D2	I/O	Video port output bit[2]
30	D1	I/O	Video port output bit[1]
31	D0	I/O	Video port output bit[0]
32	DGND	Ground	Ground for digital circuit

## Electrical Characteristics

### 1. Absolute Maximum Ratings

parameter		absolute maximum rating <sup>a</sup>
ambient storage temperature		-40°C to +125°C
supply voltage (with respect to ground)	V <sub>DD-A</sub>	4.5V
	V <sub>DD-D</sub>	3V
	V <sub>DD-IO</sub>	4.5V
electro-static discharge (ESD)	human body model	2000V
	machine model	200V
all input/output voltages (with respect to ground)		-0.3V to V <sub>DD-IO</sub> + 1V
I/O current on any input or output pin		±200 mA

- a. exceeding the absolute maximum ratings shown above invalidates all AC and DC electrical specifications and may result in permanent damage to the device. Exposure to absolute maximum rated conditions for extended periods may affect device reliability.

## 2. DC Characteristics (-20°C < Ta < 70°C)

symbol	parameter	min	typ	max	unit
<b>supply</b>					
V <sub>DD-A</sub>	supply voltage (analog)	2.6	2.8	3.0	V
V <sub>DD-DO</sub>	supply voltage (digital I/O)	1.7	1.8	3.0	V
V <sub>DD-D</sub>	supply voltage (digital core) <sup>a</sup>	1.425	1.5	1.575	V
V <sub>DD-E</sub>	supply voltage (MIPI)	1.425	1.5	1.575	V
I <sub>DD-A</sub>	active (operating) current		TBD	TBD	mA
I <sub>DD-DO</sub>	2592 x 1944 @ 15 fps <sup>b</sup>		TBD	TBD	mA
I <sub>DD-A</sub>	active (operating) current		TBD	TBD	mA
I <sub>DD-DO</sub>	720p @ 30fps		TBD	TBD	mA
I <sub>DD-A</sub>	active (operating) current		TBD	TBD	mA
I <sub>DD-DO</sub>	720p @ 60fps		TBD	TBD	mA
I <sub>DD-A</sub>	active (operating) current		TBD	TBD	mA
I <sub>DD-DO</sub>	VGA @ 30fps		TBD	TBD	mA
I <sub>DD-A</sub>	active (operating) current		TBD	TBD	mA
I <sub>DD-DO</sub>	VGA @ 60fps		TBD	TBD	mA
I <sub>DDS-SCCB</sub> <sup>c</sup>	standby current		TBD	TBD	μA
I <sub>DDS-PWDN</sub>			TBD	TBD	μA
<b>digital inputs (typical conditions: AVDD = 2.8V, DVDD = 1.5V, DOVDD = 1.8V)</b>					
V <sub>IL</sub>	input voltage LOW			0.54	V
V <sub>IH</sub>	input voltage HIGH	1.26			V
C <sub>IN</sub>	input capacitor			10	pF
<b>digital outputs (standard loading 25 pF)</b>					
V <sub>OH</sub>	output voltage HIGH	1.62			V
V <sub>OL</sub>	output voltage LOW			0.18	V
<b>serial interface inputs</b>					
V <sub>IL</sub> <sup>d</sup>	SCL and SDA	-0.5	0	0.54	V
V <sub>IH</sub> <sup>d</sup>	SCL and SDA	1.26	1.8	2.3	V

- when internal regulator is bypassed
- using internal regulator for DVDD and short DVDD with EVDD; DOVDD = 2.8V. The currents are for DVP output. MIPI output will results 5%-10% lower active current on I<sub>DD-DO</sub>
- external clock is stopped during measurement
- based on DOVDD = 1.8V

## 3. AC Characteristics (T<sub>A</sub>=25°C, V<sub>DD-A</sub>=2.8V)

symbol	parameter	min	typ	max	unit
<b>ADC parameters</b>					
B	analog bandwidth		48		MHz
DLE	DC differential linearity error		0.5		LSB
ILE	DC integral linearity error		1		LSB
	settling time for hardware reset			<1	ms
	settling time for software reset			<1	ms
	settling time for resolution mode change			<1	ms
	settling time for register setting			<300	ms

## 4. Timing Characteristics

symbol	parameter	min	typ	max	unit
oscillator and clock input					
f <sub>osc</sub>	frequency (XCLK)	6	24	27	MHz
t <sub>r</sub> , t <sub>f</sub>	clock input rise/fall time			5 (10 <sup>a</sup> )	ns

a. if using the internal PLL

**Note:** For more information of sensor please refer to the OV5647 specification.

## 5. VCM Specification

NO.	Item	Condition	Specification
1	Motor Size	Without terminal Including sensor space	8.5*8.5*3.4 mm
2	Absolute Max Current		≤100mA
3	Moving Tilt	0~22mm	<19'
4	Sensitivity		5±2μm/mA
5	Starting Current	Optical Axis: +Z direction	20~45mA
6	Hysteresis	10mA-80mA-10mA Step by 5mA	≤±10μm
7	Difference In Lens Posture	Stroke deviation that compare upward, downward with horizontal direction within lens unit	≤±100μm
8	Rated Stroke	Under 80mA input current and moving direction is upward	≥0.22mm
9	Lens Unit Weight		≤0.07g nominal

Performance Diagram

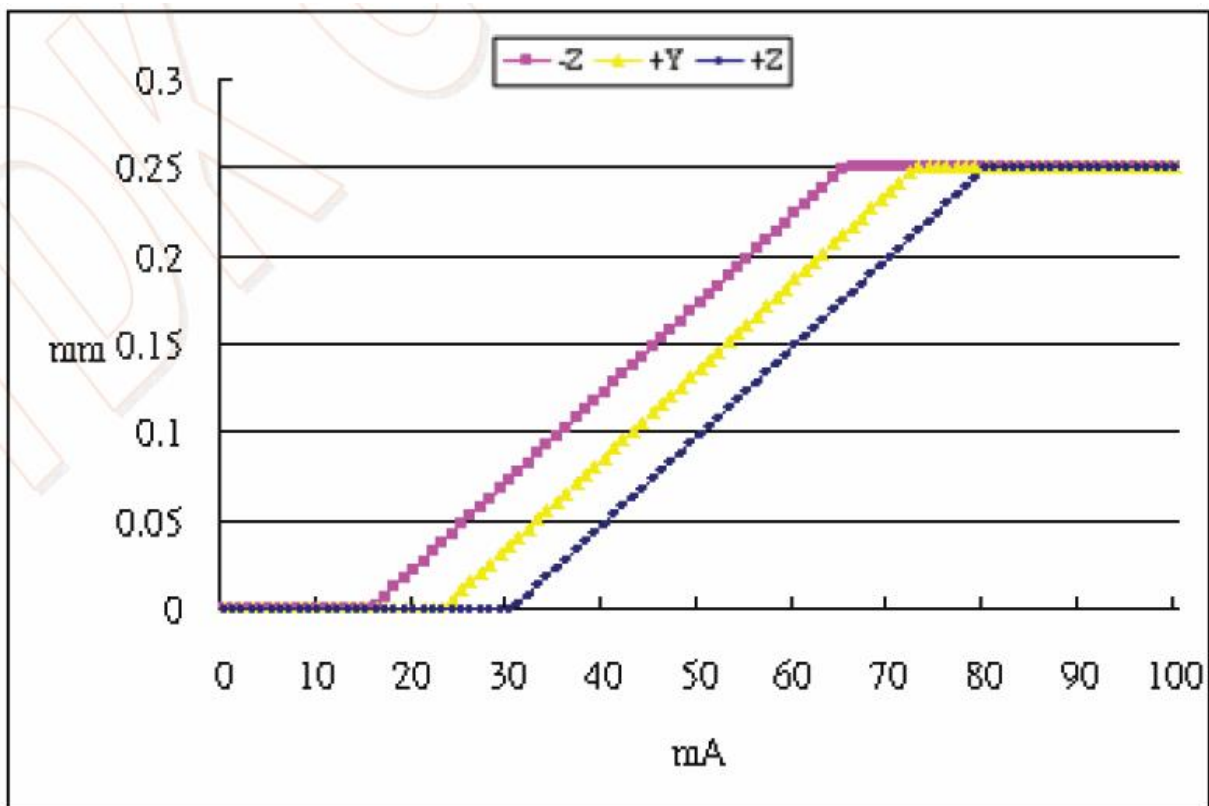



## 6. Driver IC Specification

### Description

The AD5820 is a single 10-bit DAC with 100mA output current sink capability. It features an internal reference and operates from a single 2.3V to 5.5V supply. The DAC is controlled via a 2-wire (I2C-compatible) serial interface that operates at clock rates up to 400 kHz.

The AD5820's unique and proprietary Slew Rate Control Modes allow the user to customize the output transient response thereby overcoming mechanical ringing associated with reduced form factor voice coil motors (VCMs).

The AD5820 also incorporates a power-on reset circuit, which ensures that the DAC output powers up to 0V and remains there until a valid write takes place. It has a power-down feature that reduces the current consumption of the device to 1μA maximum.

The AD5820 is designed for auto-focus, image stabilization, and optical zoom applications in camera phones, digital still cameras, and camcorders.

The AD5820 also has many industrial applications, such as controlling temperature, light, and movement, over the range  $-40^{\circ}\text{C}$  to  $+85^{\circ}\text{C}$  without derating.

The I2C address for the AD5820 is 0x18h.

### Timing Specification

$V_{DD} = 2.3\text{ V to }5.5\text{ V}$ . All specifications  $T_{MIN}$  to  $T_{MAX}$ , unless otherwise noted.

Parameter <sup>1</sup>	B Version Limit at $T_{MIN}$ , $T_{MAX}$	Unit	Description
$f_{SCL}$	400	kHz max	SCL clock frequency
$t_1$	2.5	μs min	SCL cycle time
$t_2$	0.6	μs min	$t_{HIGH}$ , SCL high time
$t_3$	1.3	μs min	$t_{LOW}$ , SCL low time
$t_4$	0.6	μs min	$t_{HD, STA}$ , start/repeated start condition hold time
$t_5$	100	ns min	$t_{SU, DAT}$ , data setup time
$t_6^2$	0.9	μs max	$t_{HD, DAT}$ , data hold time
	0	μs min	
$t_7$	0.6	μs min	$t_{SU, STA}$ , setup time for repeated start
$t_8$	0.6	μs min	$t_{SU, STO}$ , stop condition setup time
$t_9$	1.3	μs min	$t_{BUF}$ , bus free time between a stop condition and a start condition
$t_{10}$	300	ns max	$t_R$ , rise time of both SCL and SDA when receiving
	0	ns min	May be CMOS driven
$t_{11}$	250	ns max	$t_F$ , fall time of SDA when receiving
	300	ns max	$t_F$ , fall time of both SCL and SDA when transmitting
	$20 + 0.1 C_b^3$	ns min	
$C_b$	400	pF max	Capacitive load for each bus line

<sup>1</sup> Guaranteed by design and characterization; not production tested.

<sup>2</sup> A master device must provide a hold time of at least 300 ns for the SDA signal (referred to the  $V_{IH, MIN}$  of the SCL signal) to bridge the undefined region of SCL's falling edge.

<sup>3</sup>  $C_b$  is the total capacitance of one bus line in pF.  $t_9$  and  $t_7$  are measured between  $0.3 V_{DD}$  and  $0.7 V_{DD}$ .

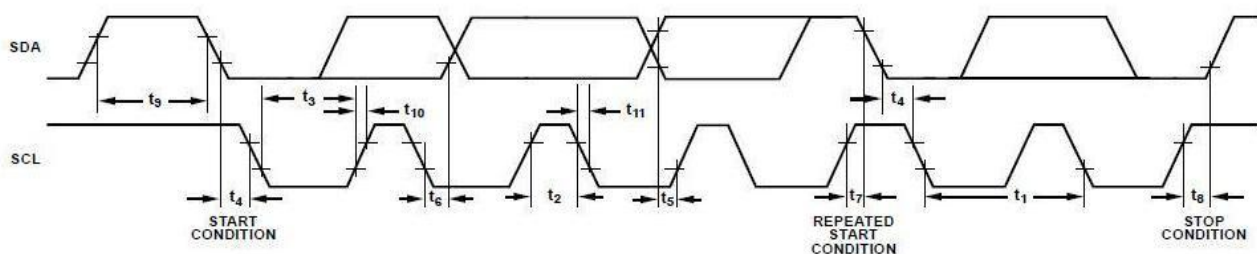

2-Wire Serial Interface Timing Diagram

### I2C Bus Operation

The AD5820 is controlled using the industry-standard I2C 2-wire serial protocol. Data can be written to or read from the DAC at data rates up to 400 kHz. After a read operation, the contents of the input register are reset to all zeros.

The I2C address is 0x18h.

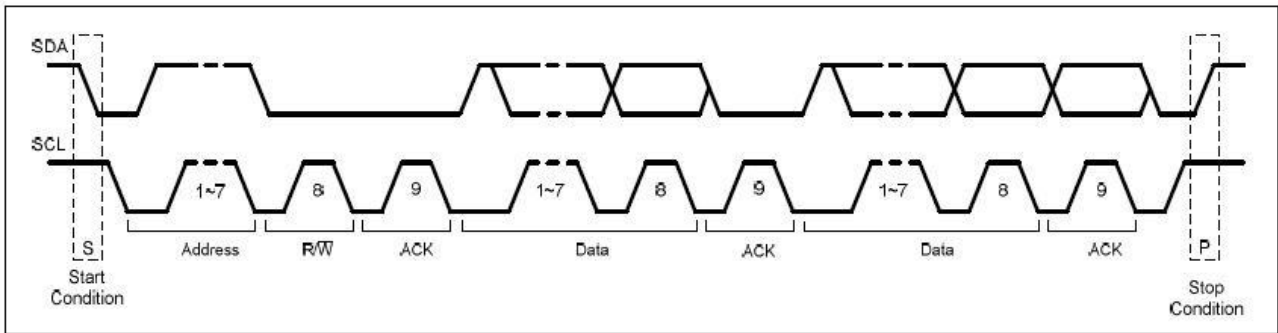

Complete I2C Data Transfer

### Write Operation

Data is written to the AD5820 high byte first, MSB first, and is shifted into a 16-bit input register. After all data is shifted in, data from the input register is transferred to the DAC register.

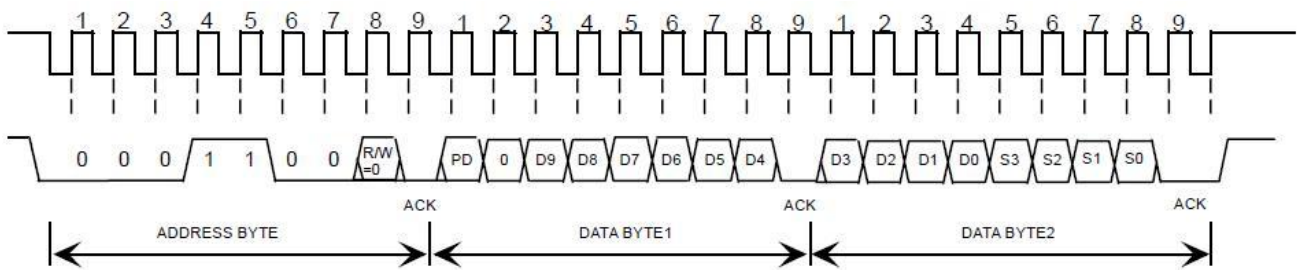

Write Operation R/W = 0

### Read Operation

During a read operation, data is read in the same bit order.

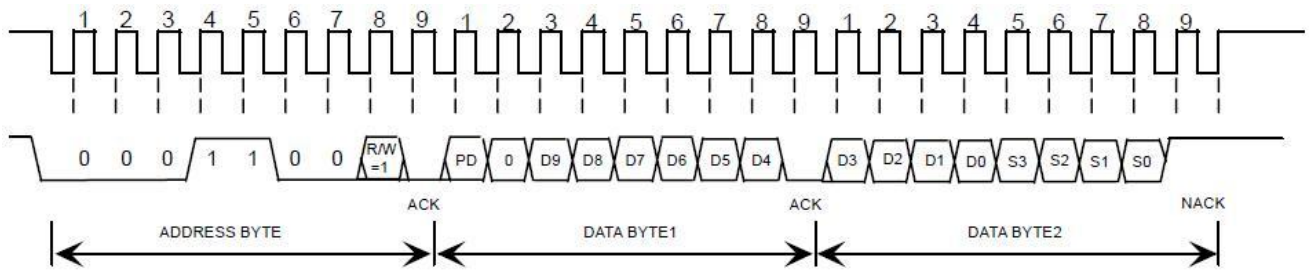

Read Operation R/W = 1

### Data Format

Bit 15, the PD bit is a software power down enable. When set to 1, the output circuitry is disabled and the AD5820 goes into a low power mode. The digital circuitry and I2C interface is still active in this mode. When the PD bit is reset back to zero, the DAC powers up to the value written to the DAC bits at the same time.

Bit 13 to bit 4 are DAC data bits D9 to D0. Bit14 is unused / don't care.

Serial Data Bits	High Byte								Low Byte							
	SD7	SD6	SD5	SD4	SD3	SD2	SD1	SD0	SD7	SD6	SD5	SD4	SD3	SD2	SD1	SD0
Input Register	R15	R14	R13	R12	R11	R10	R9	R8	R7	R6	R5	R4	R3	R2	R1	R0
Function	PD	1	D9	D8	D7	D6	D5	D4	D3	D2	D1	D0	S3	S2	S1	S0

### Mechanical Drawing

ROHS

CM5280-0500BA-E Camera Module

Customer No.:

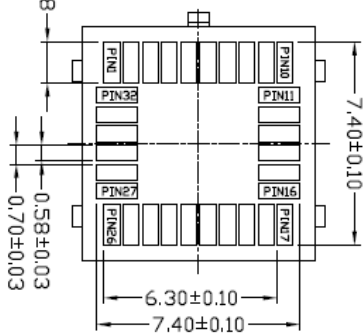
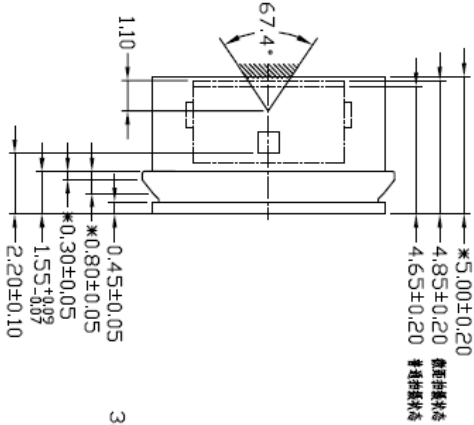
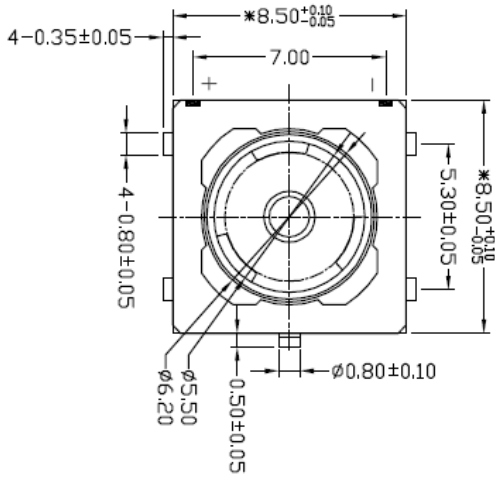

主要参数 (Module Specification)	
焦距 (FPL)	3.37 mm
光圈 (F. NO)	2.8
视场角 (View angle)	67.4°
畸变 (Distortion)	< 1 %
景深 (focusing Range)	10 cm~Infinity
感光芯片 (Chip Type)	OV5647
像素 (Array Size)	5.0M
镜头类型 (lens Size)	1/4INCH AP+IR

注: 1.\*为关键尺寸:

- CAM\_ID拉底处理;
- 配合连接器: QLE9132-8701F;
- Driver IC: AD5820

DVDD<1.5V+/-5%>  
AVDD<2.6V~-3.0V>  
DDVDD<1.7V~-3.0V>

CUSTOMER APPROVE

Mechanical Electrical

更改holder卡位	20100612
修改模组公差	20100612
修改模组高度	2010.04.30
CONTENT	DATE

AMEND

更改holder卡位

更改holder卡位	20100612
修改模组公差	20100612
修改模组高度	2010.04.30
CONTENT	DATE

手机摄像头模组

更改holder卡位

更改holder卡位	20100612
修改模组公差	20100612
修改模组高度	2010.04.30
CONTENT	DATE

TRULY OPTO-ELECTRONICS LTD.

PRODUCT NO. CM5280-0500BA-E

PRODUCT NO.	CM5280-0500BA-E	DRAW. NO.	REV
DWN	吴兴发 20100430	DSN	吴兴发 20100430
CHKD	赖路平 20100430	APPD	刘铁楠 20100430
MKT IN SCALE UNIT mm SHEET			

Actuator Specification	
Type	VCM Parameter
Control Mode	IIC
Supply Voltage	2.6V~3.1V
Coil Resistance	23±3 ohm
Rated Current	≤85mA
Rated Stroke	≥0.22mm

32PIN DESCRIPTION	PIN NO	NAME
1	FLASH	
2	DGND	
3	CAM_ID	
4	D9	
5	D8	
6	D7	
7	D6	
8	D5	
9	D4	
10	DGND	
11	DGND	
12	VSYNC	
13	HREF	
14	PVDIN	
15	PCLK	
16	DGND	
17	AF_VDD	
18	AVDD	
19	AGND	
20	MCLK	
21	RESET	
22	IOVDD	
23	DVDD	
24	SIDD	
25	SDIC	
26	AF_PVDN	
27	DGND	
28	D3	
29	D2	
30	D1	
31	D0	
32	DGND	

### Appearance Specification

NO.	Item	Standard	Importance Class
1	Top side of Lens	No obvious impurity and oil impurity on the front of lens within the half area; The defect(unfeeling) limitation: width $\leq$ 1mm, length $\leq$ 2mm, the defect number $\leq$ 2; No feeling defect; The width of defects and gaps on the outside of Lens $\leq$ 0.3mm. Others are unlimited.	A
2	Screw glue	Normally screw glue shall be symmetrical distributed around lens circle side. Particular circs, glue distribution must not disturb customer's assembly operation.	A
3	L1 Glass	No defect and dust check from 45° angle under the reflexing light and from 0° under the highlight	A
4	Holder	No obvious impurity and distortion of outline. The width and length of defect is unlimited, the depth $\leq$ 0.1mm and $\leq$ 1/4 of the thickness of Holder.	B
5	Sealed glue	Sealed glue distributing between holder and FPC must be symmetrical and smooth. Not allow glue leakage and asymmetric thickness. After holder assembly, the thickness distance between one side and its opposite side shall be less than 0.2mm. Excess glue over the holder shall not make the outside dimension be out of control.	A
6	FPC/PCB	Edge defect limitation: width $\leq$ 1/2H (H is minimum.), length $\leq$ 1mm, defect numbers per edge $\leq$ 2(No tearing gap inby edge for FPC); Edge outshoot limitation (width $\leq$ 0.3mm, length $\leq$ 1mm). No obvious impurity and crease on the surface. If there was shield film on the surface, the spot size of the film shall be less than 0.3mm $\times$ 1mm and no line is exposed. If it was not be cleaned and did not influence the total thickness, it would be permitted. Label and mark shall be clear enough to be discerned.	A
7	Connector	No dust, fingerprint, and not allows to turning colors, distortion; Solder must be well; No open circuit or short circuit	A

8	Gold finger	No dust, fingerprint, and not allows to turning colors, burned, unsmoothed and peeled; No open circuit or short circuit; The defect width shall be smaller than 20% of gold finger's width. No copper/nickel exposed in defect. Numbers of defected pin shall be less than 3. The defect limitation:width $\leq$ 0.08mm,length $\leq$ 5mm.	A
9	Stiffener	Holder anchor pole length overtopping the steel plate shall be less than 0.2mm. No dust, rust and deep scratch on the steel surface without Double coated tapes.	B
10	Double coated tapes	Adhered direction shall be right. Not allows to excess steel plate edge. No alveoli and stick. Not allows to peel glue and rip protective paper when tear the protective paper.	B
11	Protective film	No dust in the glue side. Not allows to float or drop. Adhered direction shall be right.	B

**Remark:**

## 1. The definition of the appearance importance class

A: The defect can be found in the finished product, or have obvious visual differences from good products, such as crack, defect and dust, or influence image quality, or are appointed by the customer. We will emphasize these items and check all products.

B: The defect can be found in the finished product and has visual difference from the good one, but will not affect customer's aesthetic judgement. Or the defect can not be found in the finished product and will not generate functional problem, but will slightly influence sequential manufacture process or condition. We will supervise these items in the manufacturing process and check products selectively.

## 2. Sampling standard

Referenced standard: GB/T 2828.1-2003/ISO 2859-1:1999 and ANSI/ASQC.4-1993 II

### Image Specification

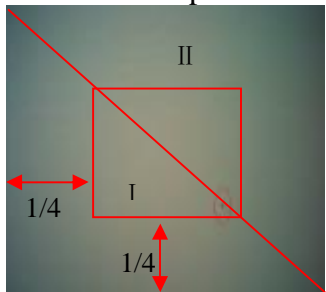
NO.	Item	Standard	Important Class
1	TV Line	Center $\geq$ 1000 8 point of 0.7 viewing field $\geq$ 800	A
2	Shading	TBD	A
3	Dust	No dust in the center viewing area; Border area according to the limit samples	A
4	Dead pixel	No in the viewing area.	A
5	Wound pixel 	I area: Blemish number $\leq$ 1 II area: Blemish number $\leq$ 4	B
6	Color	TBD	B
7	Gray Scale	TBD	B
8	Distortion	$<$ 1%	B
9	Flare	No flare in 45° viewing angle; No ghost in full viewing angle	B

**QA Plan**

NO.	Item	Sampling frequency	Measure	Remark
Image and reliability item				
1	TV Line	AQL 0.65 II Class	Same as production	100% Inspection
2	Shading	AQL 0.65 II Class	Same as production	100% Inspection
3	Dust	AQL 0.65 II Class	Same as production	100% Inspection
4	Dead pixel	AQL 0.65 II Class	Same as production	100% Inspection
5	Wound pixel	AQL 1.5 II Class	Same as production	100% Inspection
6	Color	AQL 1.5 II Class	Same as production	100% Inspection
7	Gray Scale	AQL 1.5 II Class	Same as production	100% Inspection
8	Distortion	N=5,c=0 per batch	Same as production	Sampling by QA
9	Flare	N=5,c=0 per batch	Same as production	Sampling by QA
Appearance Check Items				
1	Top side of Lens	AQL 1.0 II Class	Same as production	100% Inspection
2	Screw glue	AQL 1.0 II Class	Same as production	100% Inspection
3	L1 Glass	AQL 1.0 II Class	Same as production	100% Inspection
4	Holder	AQL 1.5 II Class	Same as production	100% Inspection
5	Sealed glue	AQL 1.0 II Class	Same as production	100% Inspection
6	FPC/PCB	AQL 1.0 II Class	Same as production	100% Inspection
7	Connector	AQL 1.0 II Class	Same as production	100% Inspection
8	Gold finger	AQL 1.0 II Class	Same as production	100% Inspection
9	Stiffener	AQL 1.5 II Class	Same as production	100% Inspection
10	Double coated tapes	AQL 1.5 II Class	Same as production	100% Inspection
11	Protective film	AQL 1.5 II Class	Same as production	100% Inspection

Sample:

Referenced standard: GB/T 2828.1-2003/ISO 2859-1:1999 and ANSI/ASQC.4-1993 II

## PRECAUTIONS FOR USING CCM MODULES

### Handing Precautions

- DO NOT try to open the unit enclosure as there is no user-serviceable component inside. To prevent damage to the camera module by electrostatic discharge, handling the camera module only after discharging all static electricity from yourself and ensuring a static-free environment for the camera module.
- DO NOT touch the top surface of the lens.
- DO NOT press down on the lens.
- DO NOT try to focus the lens.
- DO NOT put the camera module in a dusty environment.
- To reduce the risk of electrical shock and damage to the camera module, turn off the power before connect and disconnect the camera module.
- DO NOT drop the camera module more than 60 cm onto any hard surface.
- DO NOT expose camera module to rain or moisture.
- DO NOT expose camera module to direct sunlight.
- DO NOT put camera in a high temperature environment.
- DO NOT use liquid or aerosol cleaners to clean the lens.
- DO NOT make any charges or modifications to camera module.
- DO NOT subject camera module to strong electromagnetic field.
- DO NOT subject the camera module to excessive vibration or shock.
- DO NOT Impact or nip CCM module with spiculate things
- DO NOT alter, modify or change the shape of the tab on the metal frame.
- DO NOT make extra holes on the printed circuit board, modify its shape or change the positions of components to be attached.
- DO NOT damage or modify the pattern writing on the printed circuit board.
- Absolutely DO NOT modify the zebra rubber strip (conductive rubber) or heat seal connector
- Except for soldering the interface, DO NOT make any alterations or modifications with a soldering iron.
- DO NOT twist FPC of CCM.



## Apply indication

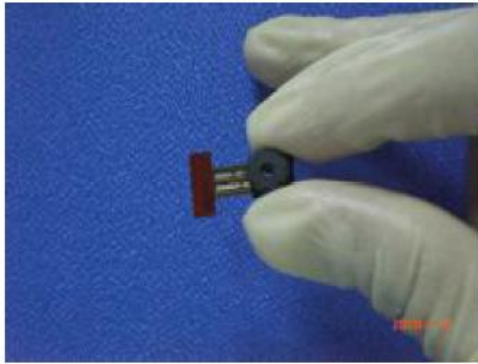

Correct

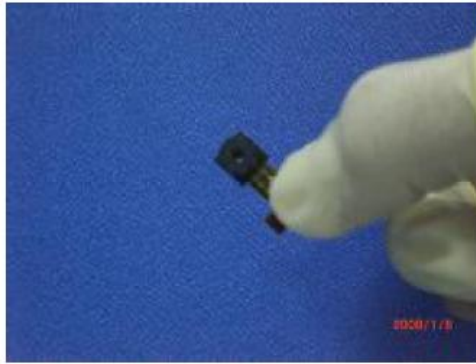

Incorrect

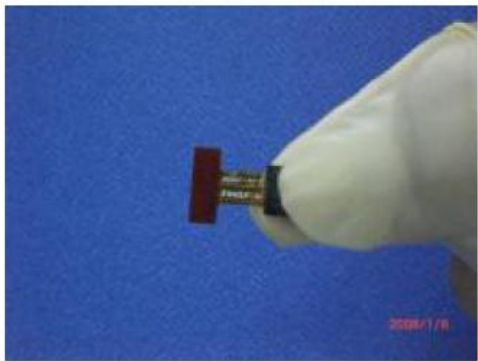

Incorrect

## Precaution for assemble the module with BTB connector:

Please note the position of the male and female connector position, don't assemble or assemble like the method which the following picture shows

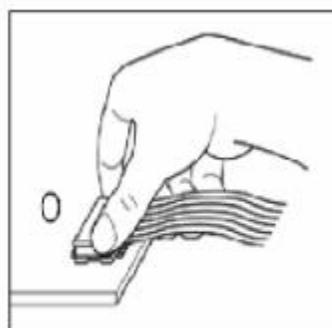
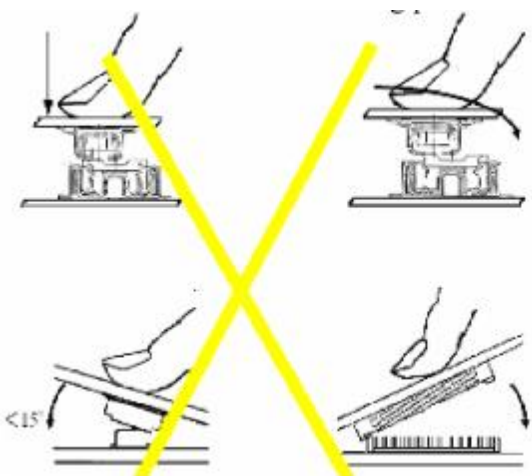

OK

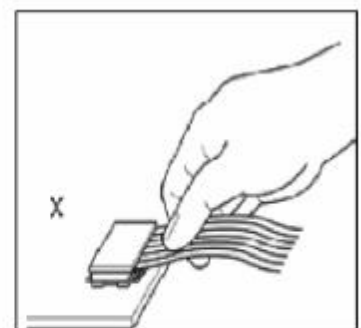

NG

**Precaution for assemble the module with ZIF connector:**

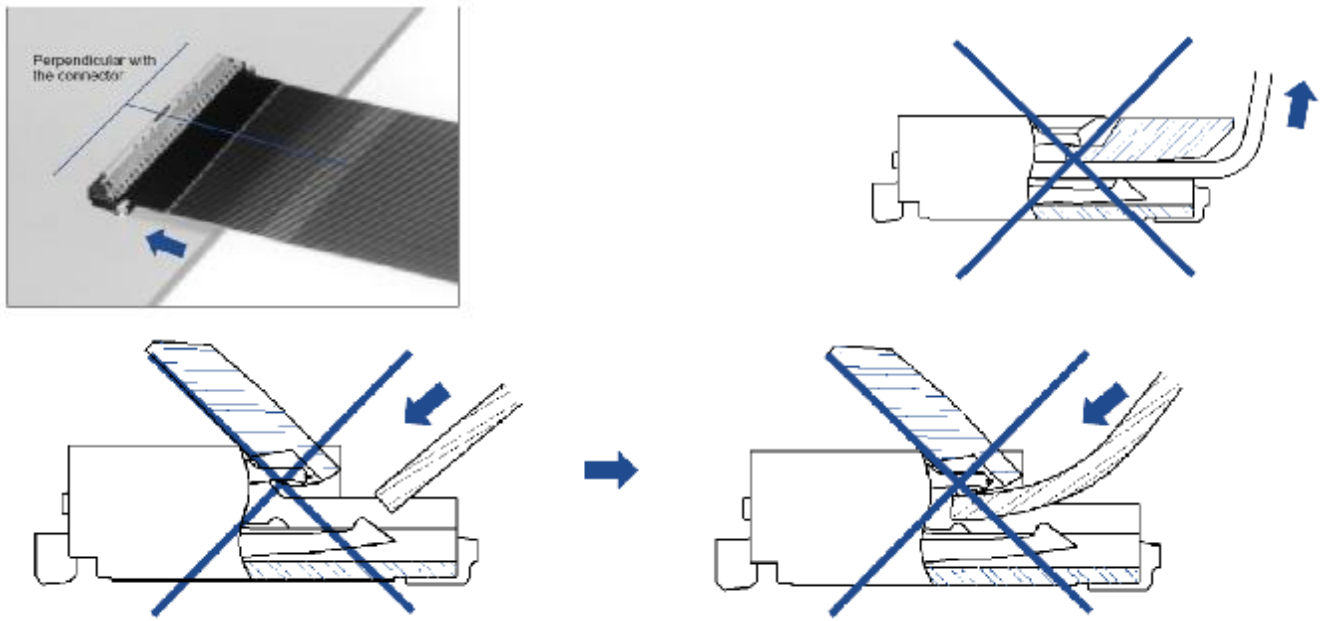

**Precaution for soldering the CCM:**

	Manual soldering	Machine drag soldering	Machine press soldering
<b>No ROHS product</b>	290°C ~350°C. Time: 3-5S.	330°C ~350°C. Speed: 4-8 mm/s.	300°C ~330°C. Time: 3-6S. Press: 0.8~1.2Mpa
<b>ROHS product</b>	340°C ~370°C. Time: 3-5S.	350°C ~370°C. Speed: 4-8 mm/s.	330°C ~360°C. Time: 3-6S. Press: 0.8~1.2Mpa

- (1) If soldering flux is used, be sure to remove any remaining flux after finishing to soldering operation. (This does not apply in the case of a non-halogen type of flux.) It is recommended that you protect the lens surface with a cover during soldering to prevent any damage due to flux spatters.
- (2) The CCM module and board should not be detached more than three times. This maximum number is determined by the temperature and time conditions mentioned above, though there may be some variance depending on the temperature of the soldering iron.

**Other precautions**

For correct using please refer to the relative criterions of electronic products.

## **Limited Warranty**

Unless agreed between TRULY and customer, TRULY will replace or repair any of its CCM modules which are found to be functionally defective when inspected in accordance with TRULY CCM acceptance standards for a period of one year from date of shipments. Cosmetic/visual defects must be returned to TRULY within 90 days of shipment. Confirmation of such date shall be based on freight documents. The warranty liability of TRULY limited to repair and/or replacement on the terms set forth above. TRULY will not be responsible for any subsequent or consequential events.

## **Return CCM under warranty**

No warranty can be granted if the precautions stated above have been disregarded. The typical examples of violations are:

- Holder is apart from module.
- Holder or Connector is anamorphic.
- Connector is turnup.
- FPC is lacerated or disconnection, and so on.

Module repairs will be invoiced to the customer upon mutual agreement. Modules must be returned with sufficient description of the failures or defects. Any connectors or cable installed by the customer must be removed completely without damaging the PCB eyelet, conductors and terminals.

## Package Specification

### Packaging Design One

Product No.	CM5280-O500BA-E	Release date		
Product name	Compact Camera Module	Releaser		
Supplier	TRULY OPTO-ELECTRONICS LTD.	Recycle	<input type="checkbox"/> YES	<input checked="" type="checkbox"/> NO
Quantity/ each box	TBD	Material for box	<input checked="" type="checkbox"/> paper <input type="checkbox"/> plastic	
Outer carton box size	405mm*290mm*290mm	Box type	<input checked="" type="checkbox"/> new <input type="checkbox"/> update	
Quantity / inner box * Quantity / outer box	TBD	Weight	g / pcs	BOX=TYPE Record of SRF Dept.
			Kg / outer box	

#### Packing Standards:

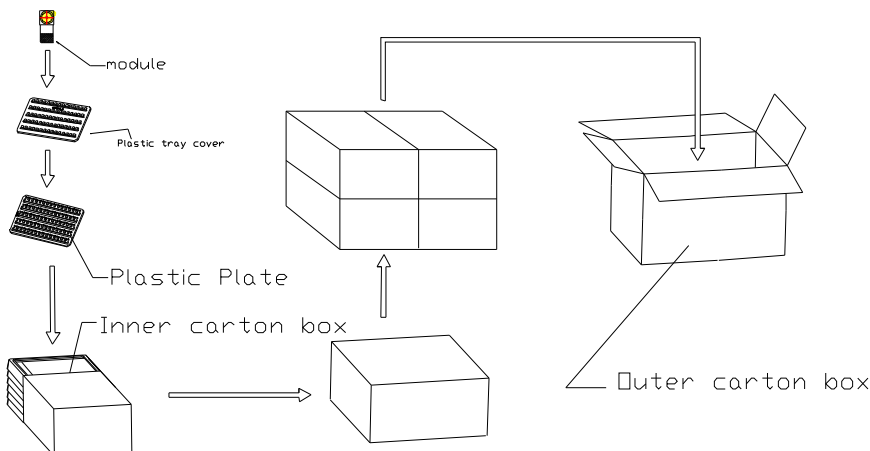

There are TBD modules each plastic plate.

There are TBD modules each inner carton box..

There are TBD modules each outer carton box.

#### Requirements of outer carton box :

1. Weight(Max): 0.75 Kg
2. Height (Max): 0.29 M
3. Prohibition: Box made by log

#### Material for Plastic tray

It is made of antistatic polystyrene which has no chemical pollution. Surface resistivity :  $10^6$  ohm/sq

## Packaging Design Two

Product No.	CM5280-O500BA-E	Release date							
Product name	Compact Camera Module	Releaser							
Supplier	TRULY OPTO-ELECTRONICS LTD.	Recycle	<input type="checkbox"/> YES <input checked="" type="checkbox"/> NO						
Quantity/ each box	TBD	Material for box	<input checked="" type="checkbox"/> paper <input type="checkbox"/> plastic						
Outer carton box size	405 mm *280 mm *170 mm	Box type	<input checked="" type="checkbox"/> new <input type="checkbox"/> update						
Quantity / inner box * Quantity / outer box	TBD	Weight	<table border="1"> <tr> <td>g / pcs</td> <td>BOX=TYPE Record of SRF Dept.</td> <td>TBD</td> </tr> <tr> <td>Kg / outer box</td> <td></td> <td>Kg(Max)</td> </tr> </table>	g / pcs	BOX=TYPE Record of SRF Dept.	TBD	Kg / outer box		Kg(Max)
g / pcs	BOX=TYPE Record of SRF Dept.	TBD							
Kg / outer box		Kg(Max)							

### Packing Standards:

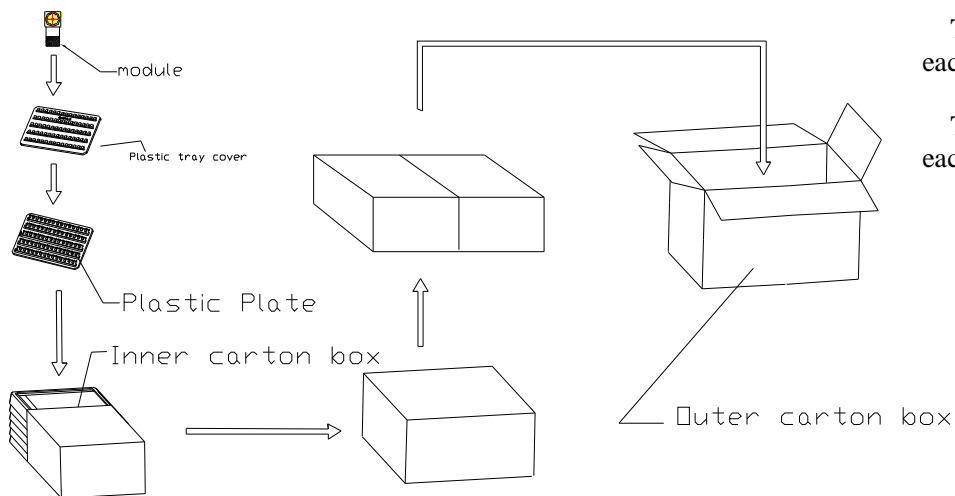

There are TBD modules each plastic plate.

There are TBD modules each inner carton box..

There are TBD modules each outer carton box.

### Requirements of outer carton box :

4. Weight(Max): 0.65 Kg
5. Height (Max): 0.17 M
6. Prohibition: Box made by log

### Material for Plastic tray

It is made of antistatic polystyrene which has no chemical pollution. Surface resistivity :  $10^6$  ohm/sq

## **PRIOR CONSULT MATTER**

- 1.①For Truly standard products, we keep the right to change material, process for improving the product property without notice on our customer.  
②For OEM products, if any change needed which may affect the product property, we will consult with our customer in advance.
2. If you have special requirement about reliability condition, please let us know before you start the test on our samples.

## **FACTORY CONTACT INFORMATION**

**FACTORY NAME:** TRULY OPTO-ELECTRONICS LTD.

**FACTORY ADDRESS:** Truly Industrial Area, ShanWei City, GuangDong, China

**FACTORY PHONE:** 86-0660-3380061    **FAX:** 86-0660-3371772