

PRODUCT : CAMERA MODULE
MODEL NO. : CM8227-B300BF-E
SUPPLIER : TRULY OPTO-ELECTRONICS LTD .
DATE : March 31, 2010



CERT. No. 946535
ISO9001
TL9000

SPECIFICATION

Revision: 1.0

CM8227-B300BF-E

If there is no special request from customer, TRULY OPTO-ELECTRONICS LTD . will not reserve the tooling of the product under the following conditions:

1. There is no response from customer in two years after TRULY OPTO-ELECTRONICS LTD submit the samples;
2. There is no order in two years after the latest mass production.

TRULY OPTO-ELECTRONICS LTD: **CUSTOMER:**

Quality Assurance Department: _____
Approved by:
Technical Department: _____

Approved by:

CONTENTS

- KEY INFORMATION
- PIN ASSIGNMENT
- ELECTRICAL CHARACTERISTICS
- MECHANICAL DRAWING
- APPEARANCE SPECIFICATION
- IMAGE SPECIFICATION
- QA PLAN
- PRECAUTIONS FOR USING CCM MODULES
- PACKAGE SPECIFICATION
- PRIOR CONSULT MATTER
- FACTORY CONTACT INFORMATION

WRITTEN BY	CHECKED BY	APPROVED BY
WANG PEI	WEI YOU XING	LIU TIE NAN

Key Information

Module No.		CM8227-B300BF-E
Module Size		6.5mm x 6.5mm x4.57mm
Sensor Type		S5K5CAGX
Array Size		2048 X 1536(QXGA)
Power supply	Core	1.8V (regulator on)
	Analog	2.8V
	I/O	1.8V/2.8V
Lens		1/5 inch 4Plastic+IR
Focus(F.NO)		2.8
View Angle		64.8°
Object distance		80cm-infinity
MAX Frame rate		15fps@QXGA,
Pixel size		1.40um x1.40um
IR Cutter		650+/-10nm
Sensor Temperature Range	Operation	-20° C to 60° C
Output Formats		YUV422, RGB565, RGB888, RAW8, RAW10, Processed Bayer, JPEG, Interleaved JPEG8 (SOSI,EOSI,SOEI,EOEI), Interleaved JPEG/Video (by data type).
Maximum Pixel(data output) clock		116MHz
ADC resolution		10Bit
IC Package		COB
Substrate		FPC

Pin Assignment

No.	Name	Pin type	Description
1	NC		
2	AGND	Power	Analog Ground
3	SDA	I/O	I2C Data
4	AVDD	Power	Analog Power 2.8V
5	SCL	I/O	I2C Clock
6	RESET	Input	System Master Reset
7	VSYNC	Tri-state Output	Vertical sync Output / Input
8	PWDN	Input	Stand-By Mode (Active low)
9	HREF	Tri-state Output	Horizontal Sync Output / Input
10	DVDD	Power	Digital power 1.8V(regulator supply for 1.5V)
11	DOVDD	Power	I/O Digital Power(2.8V-1.8V)
12	D9	Tri-state Output	Pixel Data Output / Input [9]
13	XCLK	Input	External Clock
14	D8	Tri-state Output	Pixel Data Output / Input [8]
15	DGND	Power	Digital Ground
16	D7	Tri-state Output	Pixel Data Output / Input [7]
17	PCLK	Tri-state Output	Pixel Clock Output / Input
18	D6	Tri-state Output	Pixel Data Output / Input [6]
19	D2	Tri-state Output	Pixel Data Output / Input [2]
20	D5	Tri-state Output	Pixel Data Output / Input [5]
21	D3	Tri-state Output	Pixel Data Output / Input [3]
22	D4	Tri-state Output	Pixel Data Output / Input [4]
23	D1	Tri-state Output	Pixel Data Output / Input [1]
24	D0	Tri-state Output	Pixel Data Output / Input [0]

Electrical Characteristics

1. Absolute Maximum Ratings

Characteristics	Symbol	Value	Unit
I/O Power (1.65 ~ 3.0V)	VDDIO	-0.3 to 3.8	V
Analog Power (2.8V)	VDDA	-0.3 to 3.8	
Regulator Power (1.8V)	VDDD_REG	-0.3 to 3.8	
Digital Power (1.5V)	VDDD	-0.3 to 2.0	
Operating Temperature	VOPR	-20 to +60	°C
Storage Temperature	VSTG	-40 to +85	

2. Electrical Characteristics

Symbol	Parameter	Min	Typ	Max	Unit	Note
Vtol	Tolerant Voltage	-	-	3.0	V	Power off mode
V _{DDA}	Analog Supply Voltage	2.6	2.8	3.0	V	
V _{DDD_REG}	Regulator Supply Voltage	1.7	1.8	1.9	V	
V _{DDIO1}	IO power (option 1)	2.6	2.8	3.0	V	
V _{DDIO2}	IO power (option 2)	1.65	1.8	1.95	V	
V _{DDD}	Digital Supply Voltage (regulator output)	1.4	1.5	1.6	V	
Temp	Ambient Temperature	-20	25	60	°C	
V _{ih}	DC Input Logic High	0.7*V _{DD}	-	-	V	
V _{il}	DC Input Logic Low	-	-	0.3*V _{DD}	V	
V _T	Switching Threshold	-	0.5*V _{DD}	-	V	
V _{T+}	Schmitt trigger, positive	-	-	0.7*V _{DD}	V	
V _{T-}	Schmitt trigger, negative	0.3*V _{DD}	-	-	V	
I _{ih}	High Level Input Current	-10	-	10	uA	
I _{il}	Low Level Input Current	-10	-	10	uA	
I _{ih}	High Level Input Current(pull up)	-	TBD	-	uA	
I _{il}	Low Level Input Current(pull up)	-	TBD	-	uA	
V _{oh}	Output High Voltage(@I _{oh} =-100uA)	V _{DD} -0.2	-	-	V	
V _{ol}	Output Low Voltage(@I _{ol} =100uA)	-	-	0.2	V	
f _{IN (with PLL)}	Input Operating Frequency	6	-	56	MHZ	

Symbol	Parameter	Min	Typ	Max	Unit	Note
FOUT	Output Operating Frequency	6	98	116	MHz	
COU	External Load Capacitance	-	-	5	pF	
ISTBY	Standby Current	-	-	10	uA	
P	Power Consumption M:24MHz, S:32MHz, P:60MHz VDDA/VDDIO:2.8V, VDD:1.8V	-	-	300	mW	7.5fps@fullsize
		-	-	240	mW	3.75fps@fullsize
P	Power Consumption M:24MHz, S:58MHz, P:116MHz VDDA/VDDIO:2.8V, VDD:1.8V	-	-	450	mW	15fps@fullsize
		-	-	340	mW	7.5fps@fullsize

3. Power Up/Down Sequence

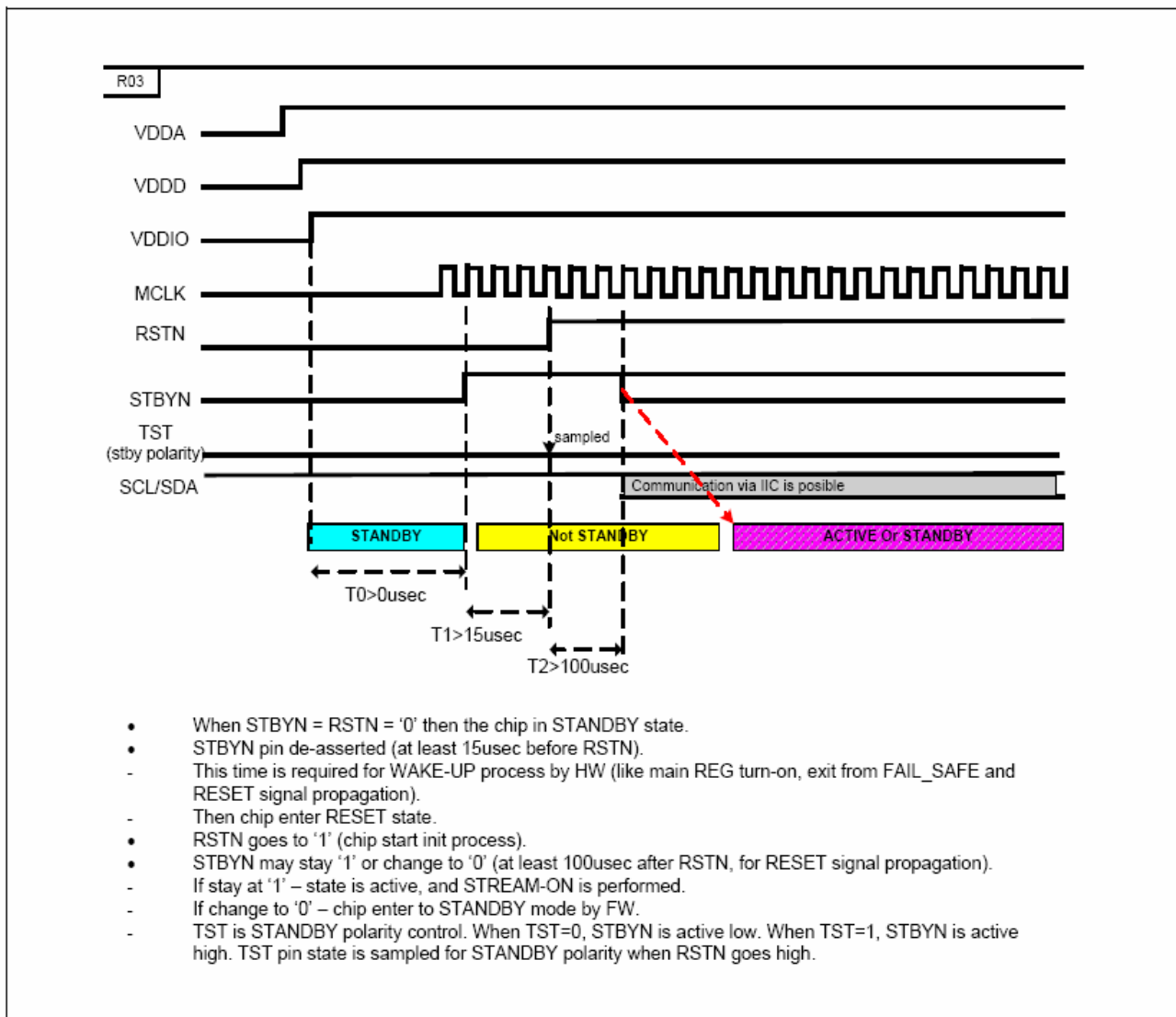

4. Stand-by Sequence

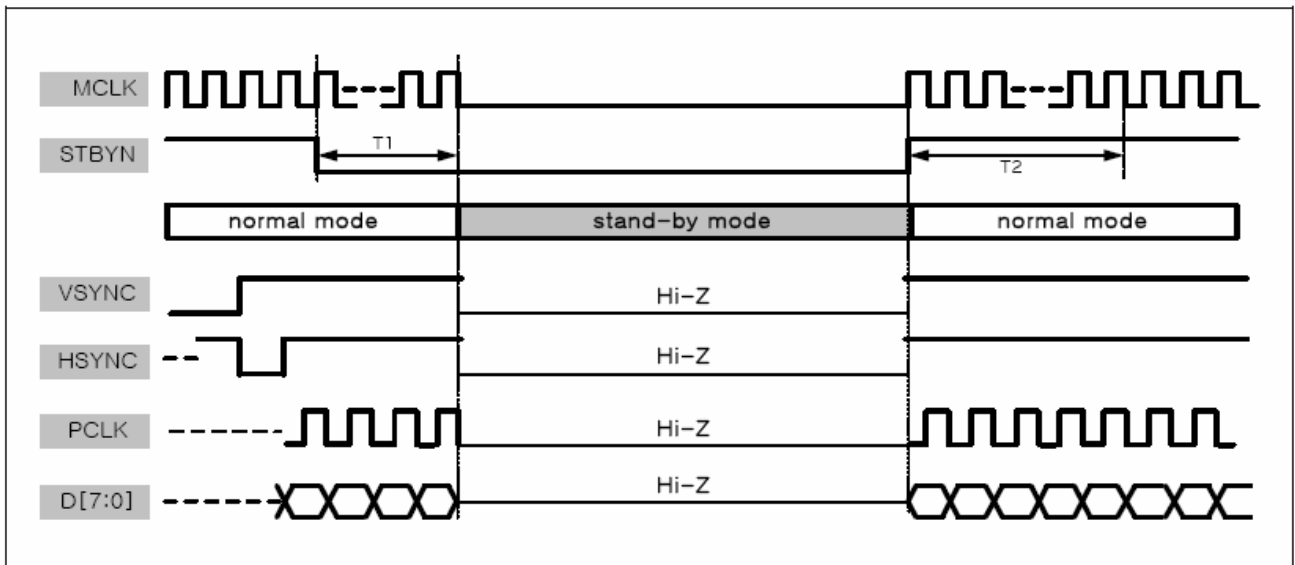

Note: For more information of sensor please refer to the S5K5CAGX specification.

ROHS

CM8227-B300BF-E Camera Module

Customer No.:

24PIN DESCRIPTION

PIN NO	NAME
1	NC
2	AGND
3	SI0D
4	AVDD_2.8V
5	SI0C
6	RESET
7	VSYNC
8	P.W/DN
9	HREF
10	DVDD_1.8V
11	DDVDD_2.8V
12	D9
13	XCLK
14	D8
15	DGND
16	D7
17	PCLK
18	D6
19	D2
20	D5
21	D3
22	D4
23	D1
24	D0

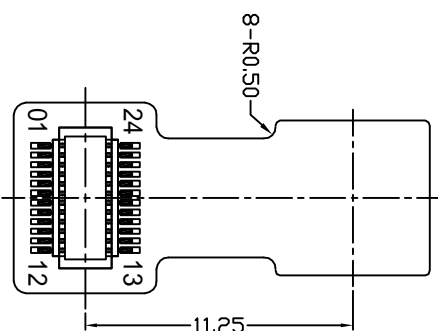
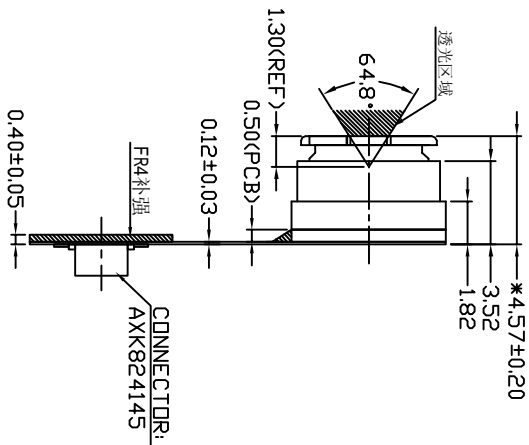
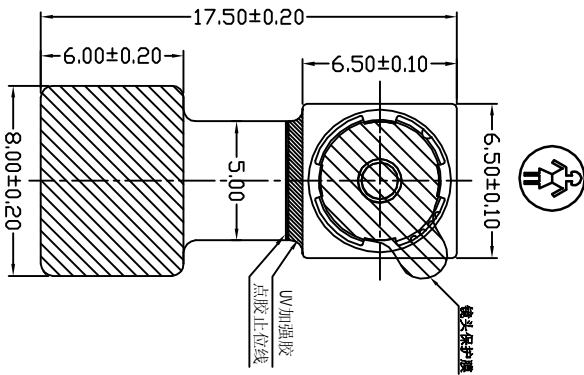

主要参数 (Module Specification)

焦距 (FPL)	2.78 mm
光圈 (F. NO)	2.8
视场角 (View Angle)	64.8°
畸变 (Distortion)	< 1 %
景深 (Focusing Range)	80 cm ~ Infinity
感光芯片 (Chip Type)	55K50AKX
像素 (Array Size)	3.0M
镜头类型 (Lens Size)	1/5INCH 4P+1R

CUSTOMER APPROVE

Mechanical

Electrical

AMEND

手机摄像模组

TOLERANCE
DECIMAL

x ± .30
xx ± .20
≤ ± 1/4

TRULY OPTO-ELECTRONICS LTD.

PRODUCT NO.

CM8227-B300BF-E

DRAW. NO.

标准品 A

AMEND	DATE	CONTENT
△		
△		
△		
ND.		

备注:
带*尺寸为关键尺寸

CHKD	刘铁楠 20091214	APPD	刘铁楠 20091214
UNIT	mm	SHEET:	

Appearance Specification

NO.	Item	Standard	Importance Class
1	Top side of Lens	No obvious impurity and oil impurity on the front of lens within the half area; The defect(unfeeling) limitation: width \leq 1mm, length \leq 2mm, the defect number \leq 2; No feeling defect; The width of defects and gaps on the outside of Lens \leq 0.3mm. Others are unlimited.	A
2	Screw glue	Normally screw glue shall be symmetrical distributed around lens circle side. Particular circs, glue distribution must not disturb customer's assembly operation.	A
3	L1 Glass	No defect and dust check from 45° angle under the reflexing light and from 0° under the highlight	A
4	Holder	No obvious impurity and distortion of outline. The width and length of defect is unlimited, the depth \leq 0.1mm and \leq 1/4 of the thickness of Holder.	B
5	Sealed glue	Sealed glue distributing between holder and FPC must be symmetrical and smooth. Not allow glue leakage and asymmetric thickness. After holder assembly, the thickness distance between one side and its opposite side shall be less than 0.2mm. Excess glue over the holder shall not make the outside dimension be out of control.	A
6	FPC/PCB	Edge defect limitation: width \leq 1/2H (H is minimum.)、 length \leq 1mm、 defect numbers per edge \leq 2(No tearing gap inby edge for FPC); Edge outshoot limitation (width \leq 0.3mm, length \leq 1mm). No obvious impurity and crease on the surface. If there was shield film on the surface, the spot size of the film shall be less than 0.3mm \times 1mm and no line is exposed. If it was not be cleaned and did not influence the total thickness, it would be permitted. Label and mark shall be clear enough to be discerned.	A
7	Connector	No dust, fingerprint, and not allows to turning colors, distortion; Solder must be well; No open circuit or short circuit	A

8	Gold finger	No dust, fingerprint, and not allows to turning colors, burned, unsmoothed and peeled; No open circuit or short circuit; The defect width shall be smaller than 20% of gold finger's width. No copper/nickel exposed in defect. Numbers of defected pin shall be less than 3. The defect limitation: width \leq 0.08mm,length \leq 5mm.	A
9	Stiffener	Holder anchor pole length overtopping the steel plate shall be less than 0.2mm. No dust, rust and deep scratch on the steel surface without Double coated tapes.	B
10	Double coated tapes	Adhered direction shall be right. Not allows to excess steel plate edge. No alveoli and stick. Not allows to peel glue and rip protective paper when tear the protective paper.	B
11	Protective film	No dust in the glue side. Not allows to float or drop. Adhered direction shall be right.	B

Remark:

1. The definition of the appearance importance class

- A: The defect can be found in the finished product, or have obvious visual differences from good products, such as crack, defect and dust, or influence image quality, or are appointed by the customer. We will emphasize these items and check all products.
- B: The defect can be found in the finished product and has visual difference from the good one, but will not affect customer's aesthetic judgement. Or the defect can not be found in the finished product and will not generate functional problem, but will slightly influence sequential manufacture process or condition. We will supervise these items in the manufacturing process and check products selectively.

2. Sampling standard

Referenced standard: GB/T 2828.1-2003/ISO 2859-1:1999 and ANSI/ASQC.4-1993 II

Image Specification

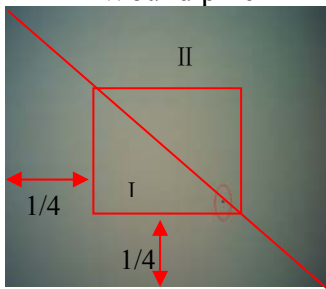
NO.	Item	Standard	Important Class
1	TV Line	Center ≥ 900 8 point of 0.7 viewing field ≥ 800	A
2	Shading	The lightness of 90% viewing area $\geq 40\%$ of center lightness(Lens correction Shading [Turn off]); The lightness of 90% viewing area $\geq 60\%$ of center lightness(Lens correction Shading [Turn on])	A
3	Dust	No dust in the center viewing area; Border area according to the limit samples	A
4	Dead pixel	No in the viewing area.	A
5	Wound pixel 	I area: Blemish number ≤ 2 II area: Blemish number ≤ 6	B
6	Color	Color distortion ratio of center $\pm 15\%$	B
7	Gray Scale	Margin of two near scales' brightness ≥ 6	B
8	Distortion	$< 1\%$	B
9	Flare	No flare in 45° viewing angle; No ghost in full viewing angle	B

QA Plan

NO.	Item	Sampling frequency	Measure	Remark
Image and reliability item				
1	TV Line	AQL 0.65 II Class	Same as production	100% Inspection
2	Shading	AQL 0.65 II Class	Same as production	100% Inspection
3	Dust	AQL 0.65 II Class	Same as production	100% Inspection
4	Dead pixel	AQL 0.65 II Class	Same as production	100% Inspection
5	Wound pixel	AQL 1.5 II Class	Same as production	100% Inspection
6	Color	AQL 1.5 II Class	Same as production	100% Inspection
7	Gray Scale	AQL 1.5 II Class	Same as production	100% Inspection
8	Distortion	N=5,c=0 per batch	Same as production	Sampling by QA
9	Flare	N=5,c=0 per batch	Same as production	Sampling by QA
Appearance Check Items				
1	Top side of Lens	AQL 1.0 II Class	Same as production	100% Inspection
2	Screw glue	AQL 1.0 II Class	Same as production	100% Inspection
3	L1 Glass	AQL 1.0 II Class	Same as production	100% Inspection
4	Holder	AQL 1.5 II Class	Same as production	100% Inspection
5	Sealed glue	AQL 1.0 II Class	Same as production	100% Inspection
6	FPC/PCB	AQL 1.0 II Class	Same as production	100% Inspection
7	Connector	AQL 1.0 II Class	Same as production	100% Inspection
8	Gold finger	AQL 1.0 II Class	Same as production	100% Inspection
9	Stiffener	AQL 1.5 II Class	Same as production	100% Inspection
10	Double coated tapes	AQL 1.5 II Class	Same as production	100% Inspection
11	Protective film	AQL 1.5 II Class	Same as production	100% Inspection

Sample:

Referenced standard: GB/T 2828.1-2003/ISO 2859-1:1999 and ANSI/ASQC.4-1993 II

PRECAUTIONS FOR USING CCM MODULES

Handing Precautions

—DO NOT try to open the unit enclosure as there is no user-serviceable component inside. To prevent damage to the camera module by electrostatic discharge, handling the camera module only after discharging all static electricity from yourself and ensuring a static-free environment for the camera module.

—DO NOT touch the top surface of the lens.

—DO NOT press down on the lens.

—DO NOT try to focus the lens.

—DO NOT put the camera module in a dusty environment.

—To reduce the risk of electrical shock and damage to the camera module, turn off the power before connect and disconnect the camera module.

—DO NOT drop the camera module more than 60 cm onto any hard surface.

—DO NOT expose camera module to rain or moisture.

—DO NOT expose camera module to direct sunlight.

—DO NOT put camera in a high temperature environment.

—DO NOT use liquid or aerosol cleaners to clean the lens.

—DO NOT make any charges or modifications to camera module.

—DO NOT subject camera module to strong electromagnetic field.

—DO NOT subject the camera module to excessive vibration or shock.

—DO NOT Impact or nip CCM module with spiculate things

—DO NOT alter, modify or change the shape of the tab on the metal frame.

—DO NOT make extra holes on the printed circuit board, modify its shape or change the positions of components to be attached.

—DO NOT damage or modify the pattern writing on the printed circuit board.

—Absolutely DO NOT modify the zebra rubber strip (conductive rubber) or heat seal connector

—Except for soldering the interface, DO NOT make any alterations or modifications with a soldering iron.

—DO NOT twist FPC of CCM.

Apply indication



Correct



Incorrect

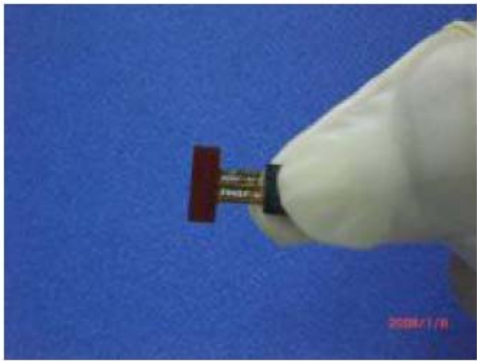

Incorrect

Precaution for assemble the module with BTB connector:

Please note the position of the male and female connector position, don't assemble or assemble like the method which the following picture shows

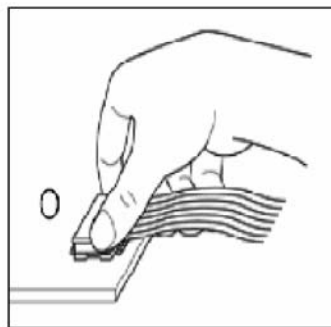
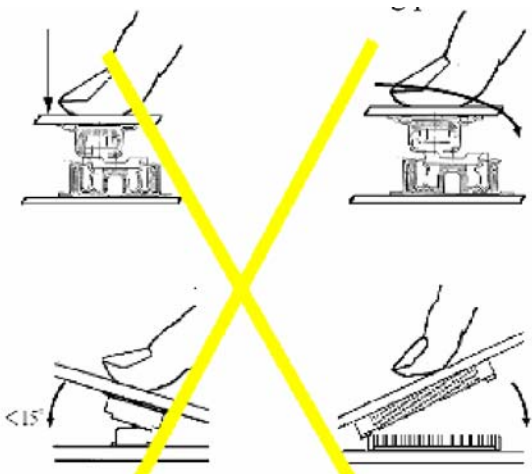

OK

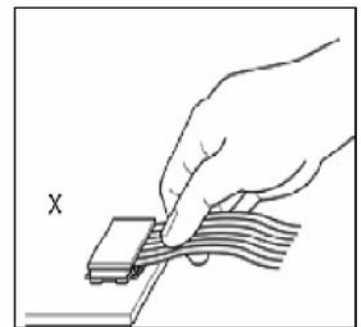

NG

Precaution for assemble the module with ZIF connector:

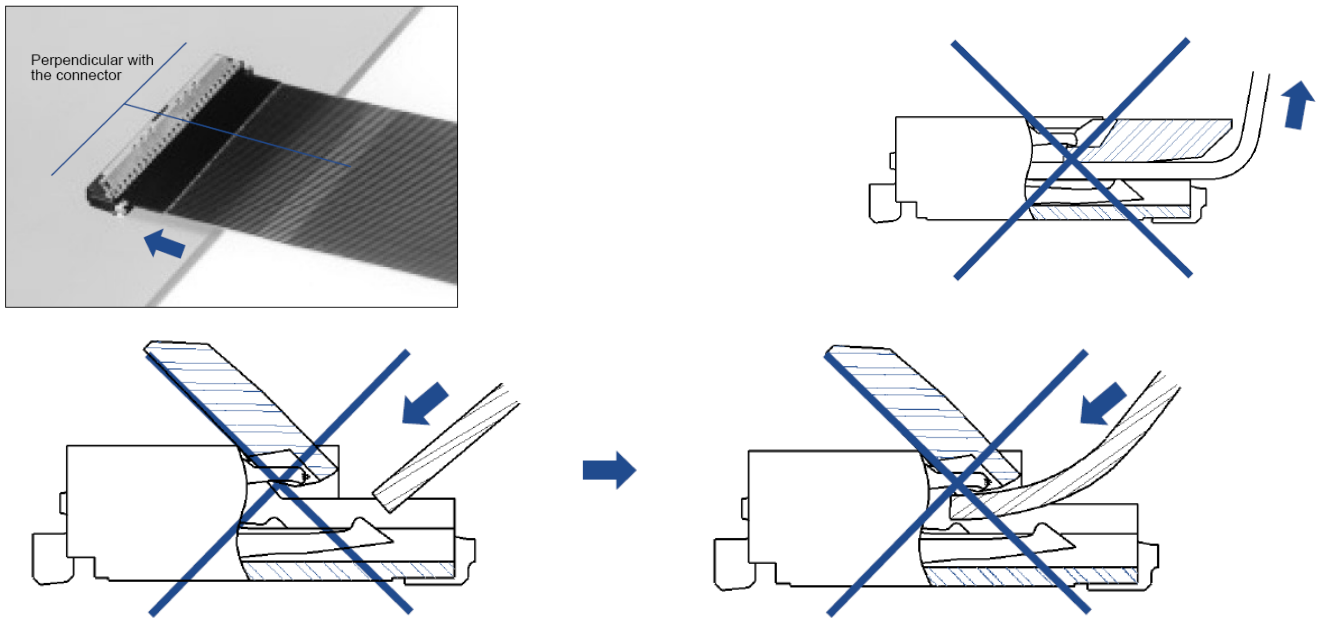

Precaution for soldering the CCM:

	Manual soldering	Machine drag soldering	Machine press soldering
No RoHS product	290°C ~350°C. Time: 3-5S.	330°C ~350°C. Speed: 4-8 mm/s.	300°C ~330°C. Time: 3-6S. Press: 0.8~1.2Mpa
RoHS product	340°C ~370°C. Time: 3-5S.	350°C ~370°C. Speed: 4-8 mm/s.	330°C ~360°C. Time: 3-6S. Press: 0.8~1.2Mpa

- (1) If soldering flux is used, be sure to remove any remaining flux after finishing to soldering operation. (This does not apply in the case of a non-halogen type of flux.) It is recommended that you protect the lens surface with a cover during soldering to prevent any damage due to flux spatters.
- (2) The CCM module and board should not be detached more than three times. This maximum number is determined by the temperature and time conditions mentioned above, though there may be some variance depending on the temperature of the soldering iron.

Other precautions

For correct using please refer to the relative criterions of electronic products.

Limited Warranty

Unless agreed between TRULY and customer, TRULY will replace or repair any of its CCM modules which are found to be functionally defective when inspected in accordance with TRULY CCM acceptance standards for a period of one year from date of shipments. Cosmetic/visual defects must be returned to TRULY within 90 days of shipment. Confirmation of such date shall be based on freight documents. The warranty liability of TRULY limited to repair and/or replacement on the terms set forth above. TRULY will not be responsible for any subsequent or consequential events.

Return CCM under warranty

No warranty can be granted if the precautions stated above have been disregarded. The typical examples of violations are:

- Holder is apart from module.
- Holder or Connector is anamorphic.
- Connector is turnup.
- FPC is lacerated or disconnection, and so on.

Module repairs will be invoiced to the customer upon mutual agreement. Modules must be returned with sufficient description of the failures or defects. Any connectors or cable installed by the customer must be removed completely without damaging the PCB eyelet, conductors and terminals.

Package Specification Packaging Design One

Product No.	CM8227-B300BF-E	Release date									
Product name	Compact Camera Module	Releaser									
Supplier	TRULY OPTO-ELECTRONICS LTD .	Recycle	<input type="checkbox"/> YES <input checked="" type="checkbox"/> NO								
Quantity/ each box	TBD	Material for box	<input checked="" type="checkbox"/> paper <input type="checkbox"/> plastic								
Outer carton box size	405mm*290mm*290mm	Box type	<input checked="" type="checkbox"/> new <input type="checkbox"/> update								
Quantity / inner box * Quantity / outer box	TBD	Weight	<table border="1"> <tr> <td></td> <td>g / pcs</td> <td>BOX=TYPE</td> <td>TBD</td> </tr> <tr> <td></td> <td>Kg / outer box</td> <td>Record of SRF Dept.</td> <td>Kg(Max)</td> </tr> </table>		g / pcs	BOX=TYPE	TBD		Kg / outer box	Record of SRF Dept.	Kg(Max)
	g / pcs	BOX=TYPE	TBD								
	Kg / outer box	Record of SRF Dept.	Kg(Max)								

Packing Standards:

There are TBD modules each plastic plate.

There are TBD modules each inner carton box..

There are TBD modules each outer carton box.

Requirements of outer carton box :

1. Weight(Max): 0.75 Kg
2. Height (Max): 0.29 M
3. Prohibition: Box made by log

Material for Plastic tray

It is made of antistatic polystyrene which has no chemical pollution. Surface resistivity : 10^6 ohm/sq

Packaging Design Two

Product No.	CM8227-B300BF-E	Release date							
Product name	Compact Camera Module	Releaser							
Supplier	TRULY OPTO-ELECTRONICS LTD .	Recycle	<input type="checkbox"/> YES <input checked="" type="checkbox"/> NO						
Quantity/ each box	TBD	Material for box	<input checked="" type="checkbox"/> paper <input type="checkbox"/> plastic						
Outer carton box size	405 mm *280 mm *170 mm	Box type	<input checked="" type="checkbox"/> new <input type="checkbox"/> update						
Quantity / inner box * Quantity / outer box	TBD	Weight	<table border="1"> <tr> <td>g / pcs</td> <td>BOX=TYPE Record of SRF Dept.</td> <td>TBD</td> </tr> <tr> <td>Kg / outer box</td> <td></td> <td>Kg(Max)</td> </tr> </table>	g / pcs	BOX=TYPE Record of SRF Dept.	TBD	Kg / outer box		Kg(Max)
g / pcs	BOX=TYPE Record of SRF Dept.	TBD							
Kg / outer box		Kg(Max)							

Packing Standards:

There are TBD modules each plastic plate.

There are TBD modules each inner carton box..

There are TBD modules each outer carton box.

Requirements of outer carton box :

4. Weight(Max): 0.65 Kg
5. Height (Max): 0.17 M
6. Prohibition: Box made by log

Material for Plastic tray

It is made of antistatic polystyrene which has no chemical pollution. Surface resistivity : 10^6 ohm/sq

PRIOR CONSULT MATTER

- 1.①For Truly standard products, we keep the right to change material, process for improving the product property without notice on our customer.
②For OEM products, if any change needed which may affect the product property, we will consult with our customer in advance.
2. If you have special requirement about reliability condition, please let us know before you start the test on our samples.

FACTORY CONTACT INFORMATION

FACTORY NAME: TRULY OPTO-ELECTRONICS LTD .

FACTORY ADDRESS: Truly Industrial Area, ShanWei City, GuangDong, China

FACTORY PHONE: 86-0660-3380061 **FAX:** 86-0660-3371772